

# MODEL 72 SIMPLEX BASKET STRAINER

Sizes 3/8" to 8" • Iron, Bronze, Carbon Steel or Stainless Steel • Threaded or Flanged

The Industry  
Standard Simplex  
Strainer



### Features

- Quick open cover – no tools needed
- Heavy wall construction
- Large capacity baskets
- Machined basket seat
- Threaded drain
- Perforated stainless basket

### Options

- Basket perforations from 1/32" to 1/2"
- Basket mesh from 20 to 400
- Monel baskets
- Viton, PTFE-encapsulated, or EPDM seals
- Vent valves
- 1/4" NPT taps
- Magnetic basket inserts
- Pressure differential gauge and switch



The Eaton Model 72 Simplex Strainer has been the industry standard simplex basket strainer for over 75 years. It's perfect for industrial and commercial applications where the line can be temporarily shut down for strainer basket cleaning or changeout. A reason for its popularity is the unusually large basket capacity. The free straining area is at least 6 times the cross sectional pipe area (even more in many sizes). No tools are needed to open the cover. The quick opening, swinging yoke can be disassembled and the basket removed in seconds. On sizes 4" and larger, a special cover clamp is provided to distribute the seating pressure and to insure positive seating of the cover.

Another feature is a threaded drain on every size strainer (fitted with a plug). This can be used as a backwash connection, if desired. Sizes 2" and larger are provided with legs for bolting to the floor for rock solid installation.

Wall thicknesses are exceptionally heavy. We have not stinted on weight to save material costs. The basket seats are precision machined to give a tight seal and prevent any material from by-passing the basket. The Eaton Model 72 Simplex Basket Strainer is a top quality, heavy duty unit designed to stand up to the most demanding of applications. There is simply no better simplex basket strainer made.

### Model 72 Simplex

Size	Material	End Connection *	Seals	Pressure Rating
3/8" to 3"	Iron and Bronze	Threaded	Buna N	200 psi @ 100F
1" to 3"	Carbon Steel		Viton®	
	Stainless Steel			
1" to 8"	Iron	Flanged 125#	Buna N	
	Bronze	Flanged 150#		
	Carbon Steel		Viton®	
	Stainless Steel			

### Mod. 72Cv Factors\*

Size	Value	Size	Value
3/8"	15.0	2"	73
1/2"	15.0	2-1/2"	125
3/4"	15.0	3"	180
1"	22.5	4"	350
1-1/4"	31.5	6"	900
1-1/2"	46.0	8"	1400

\* For water with clean, perforated basket

\* DIN flanges and BSP threads available

## Technical Details

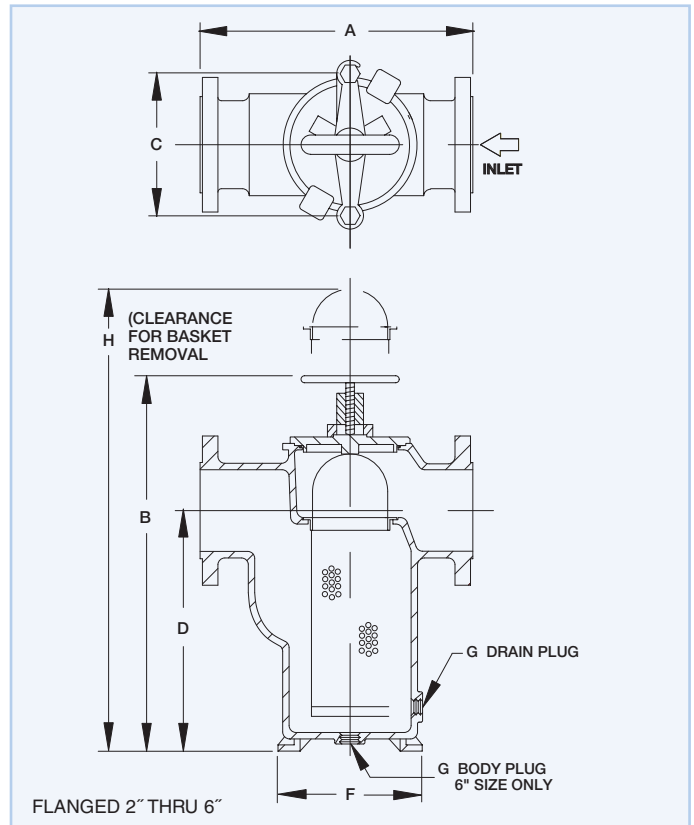
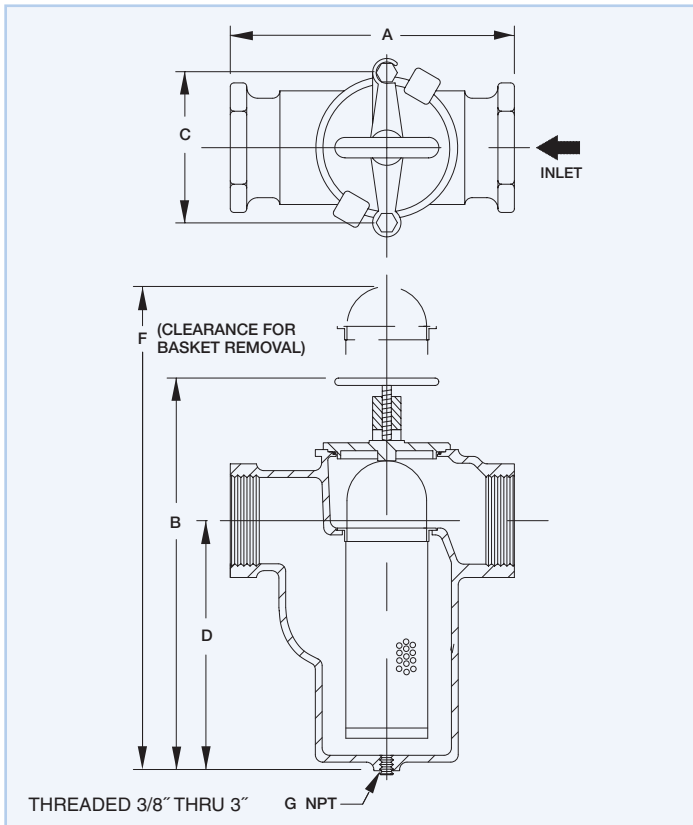

Dimensions and weights are for reference only. Contact us for certified drawings.

### Threaded Model 72 Dimensions (in / mm)

Pipe Size	A	B	C	D	E	F	G	H	Net Wt. - lb / kg			
									Bronze	Carbon Steel	Iron	Stainless Steel
3/8	4.00 / 102	6.63 / 168	2.88 / 73	4.00 / 102	2.38 / 60	11 / 279	3/8 / 10	-	4 / 1.8	-	4 / 1.8	-
1/2	4.00 / 102	6.63 / 168	2.88 / 73	4.00 / 102	2.38 / 60	11 / 279	3/8 / 10	-	4 / 1.8	-	4 / 1.8	-
3/4	5.38 / 137	8.38 / 213	4.00 / 102	5.00 / 127	3.06 / 78	13 / 330	1/2 / 15	-	8 / 3.6	-	7 / 3.2	-
1	5.38 / 137	8.38 / 213	4.00 / 102	5.00 / 127	3.06 / 78	13 / 330	1/2 / 15	-	8 / 3.6	7 / 3.2	7 / 3.2	7 / 3.2
1-1/4	6.75 / 172	9.88 / 251	4.88 / 124	5.88 / 149	3.88 / 99	14 / 356	1/2 / 15	-	13 / 6	-	12 / 6	-
1-1/2	7.25 / 184	11.00 / 279	4.88 / 124	7.00 / 178	4.00 / 102	16 / 406	3/4 / 20	-	16 / 7	15 / 7	15 / 7	16 / 7.3
2	8.75 / 222	13.38 / 340	6.75 / 172	7.63 / 194	5.13 / 130	21 / 533	1-1/4 / 32	-	32 / 15	36 / 16	28 / 13	31 / 14
2-1/2	10.38 / 264	14.88 / 378	8.00 / 203	8.63 / 219	6.38 / 162	26 / 660	1-1/2 / 40	-	49 / 22	52 / 24	42 / 19	51 / 23
3	11.50 / 292	17.75 / 468	8.00 / 203	11.38 / 298	6.63 / 168	28 / 711	1-1/2 / 40	-	60 / 27	60 / 27	52 / 23	60 / 27

### Flanged Model 72 Dimensions (in / mm)

2	10.50 / 268	13.75 / 349	6.75 / 172	7.63 / 194	5.13 / 130	6.25 / 159	3/8 / 10	20.00 / 508	49 / 22.3	36 / 16	36.5 / 17	36 / 16
2-1/2	11.63 / 295	15.63 / 397	8.00 / 203	8.88 / 226	6.38 / 162	7.63 / 194	3/8 / 10	23.00 / 584	64 / 29.1	63 / 27	54 / 25	63 / 29
3	13.13 / 334	18.00 / 457	8.00 / 203	10.63 / 270	6.50 / 165	8.00 / 203	3/8 / 10	27.00 / 686	85 / 38.6	-	76 / 35	-
3	13.13 / 334	18.75 / 476	7.94 / 202	12.00 / 305	6.50 / 165	8.00 / 203	1/2 / 15	27.00 / 686	-	86 / 39	-	86 / 39
4	16.75 / 425	19.88 / 505	10.75 / 273	10.75 / 273	9.63 / 245	11.38 / 289	1/2 / 15	30.00 / 762	140 / 63.6	-	125 / 55	-
4	17.25 / 438	19.88 / 505	10.69 / 272	10.69 / 272	9.25 / 235	11.38 / 289	1/2 / 15	30.00 / 762	-	130 / 59	-	130 / 59
5	18.13 / 461	25.13 / 638	10.75 / 273	15.25 / 387	10.00 / 254	11.38 / 289	1/2 / 15	41.00 / 1041	182 / 82.7	-	170 / 77.5	-
6	19.63 / 499	28.50 / 724	10.69 / 272	18.38 / 467	10.00 / 254	11.38 / 289	1/2 / 15	46.00 / 1168	270 / 122.7	235 / 107	200 / 91	235 / 107
8	27.00 / 686	40.50 / 1029	-	27.00 / 686	13.75 / 349	17.50 / 445	1/2 / 15	60.00 / 1524	600 / 272.7	550 / 250	500 / 227	550 / 250